

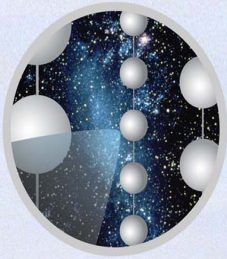

# IceCube – High Energy Results

*Greg Sullivan*  
*University of Maryland*

Neutrinos Beyond IceCube  
24 April 2014



# The IceCube Collaboration

43 Institutions  
~220 collaborators



## Funding Agencies

Fonds de la Recherche Scientifique (FRS-FNRS)  
 Fonds Wetenschappelijk Onderzoek-Vlaanderen (FWO-Vlaanderen)  
 Federal Ministry of Education & Research (BMBF)  
 German Research Foundation (DFG)

Deutsches Elektronen-Synchrotron (DESY)  
 Japan Society for the Promotion of Science (JSPS)  
 Knut and Alice Wallenberg Foundation  
 Swedish Polar Research Secretariat  
 The Swedish Research Council (VR)

University of Wisconsin Alumni Research Foundation (WARF)  
 US National Science Foundation (NSF)

# Cosmic Rays and Neutrinos

Driving theme: Origin of Cosmic Rays

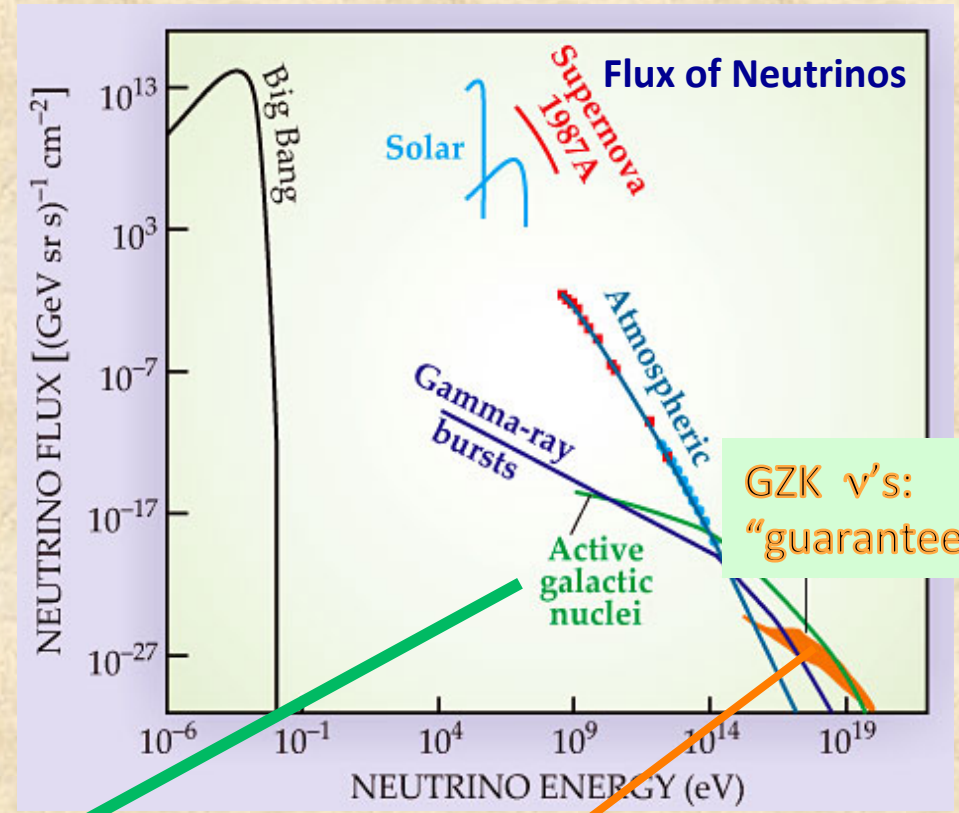
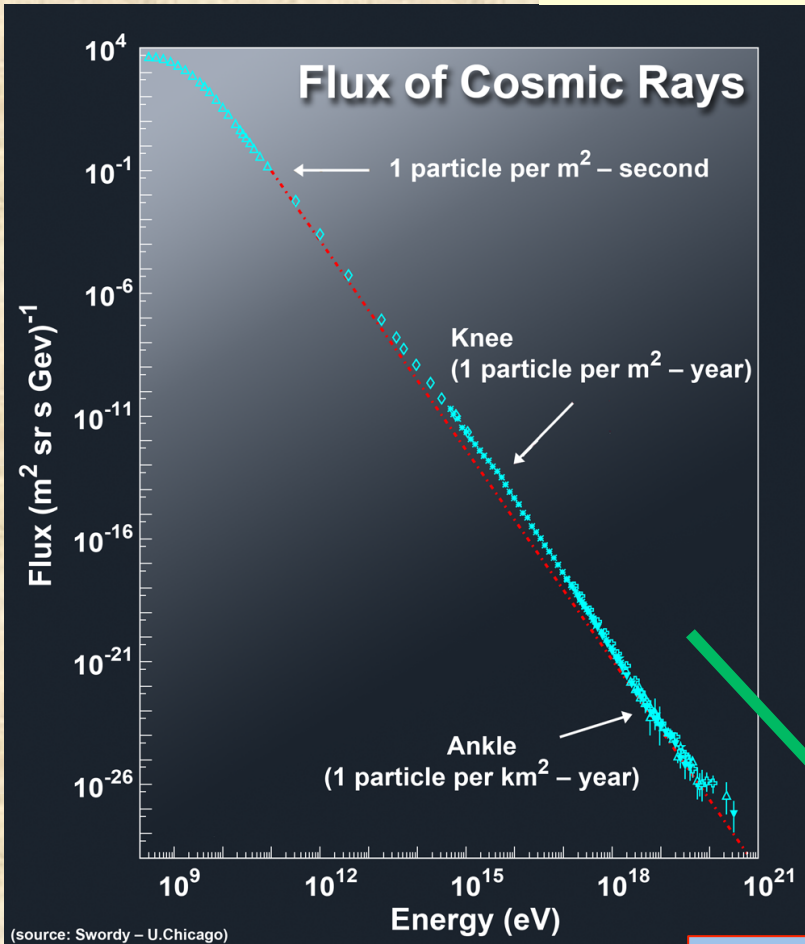

**CR –  $\nu$  connection**

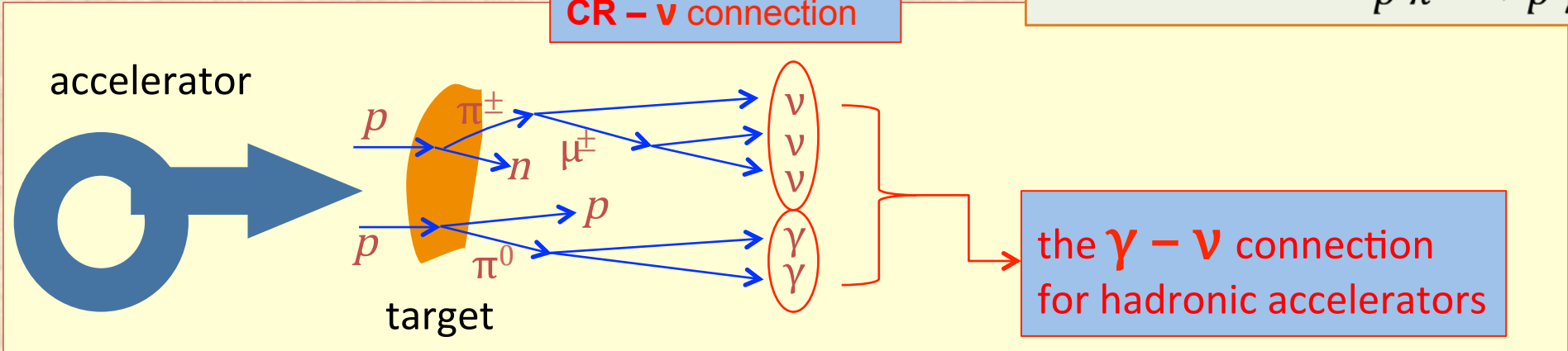
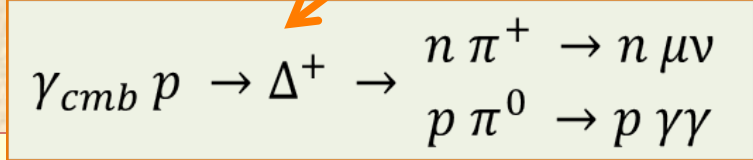

# IceCube Detector

Detector Completion Dec 2010

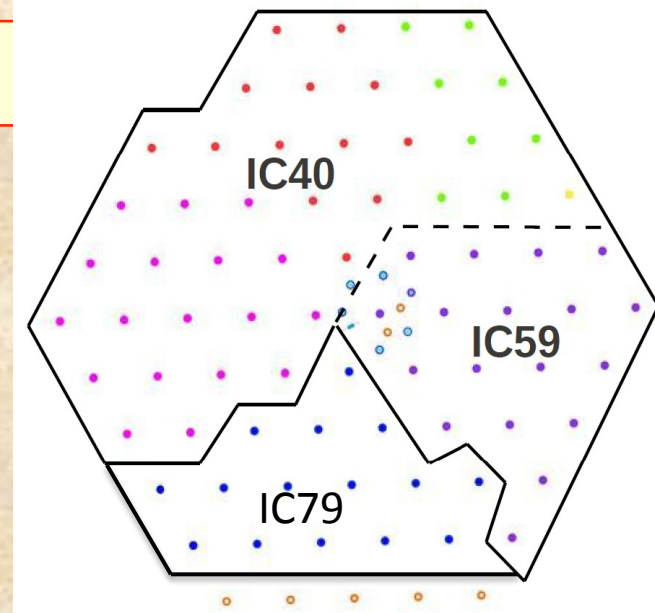
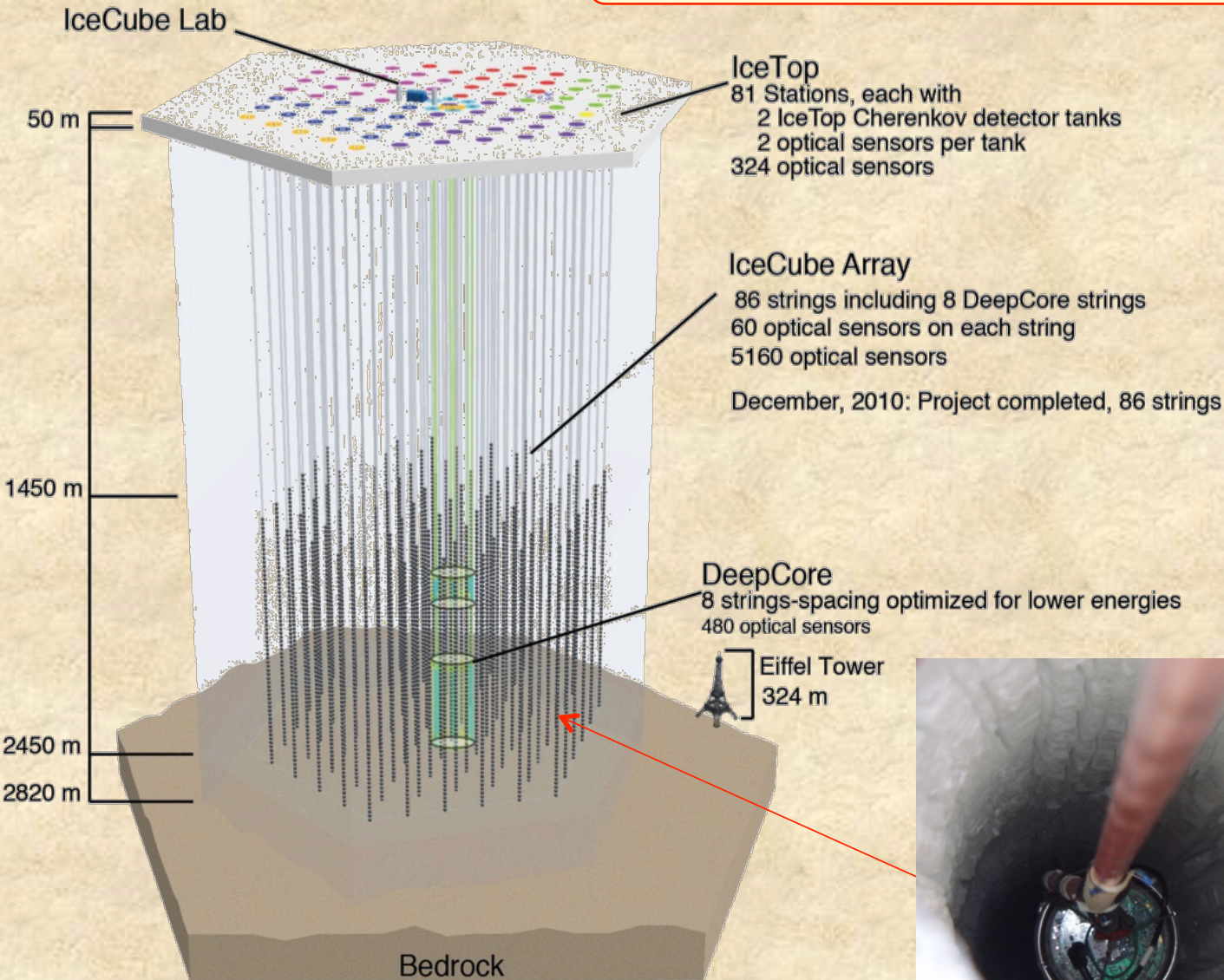

- 9 strings (2006)
- 22 strings (2007)
- 40 strings (2008)
- 59 strings (2009)
- 79 strings (2010)
- 86 strings (2011)

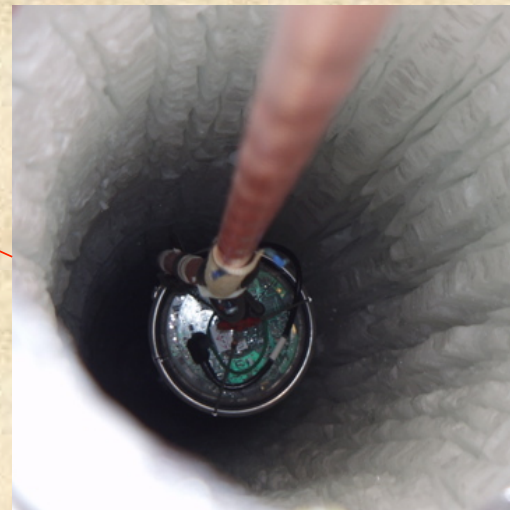

# Detection Methods

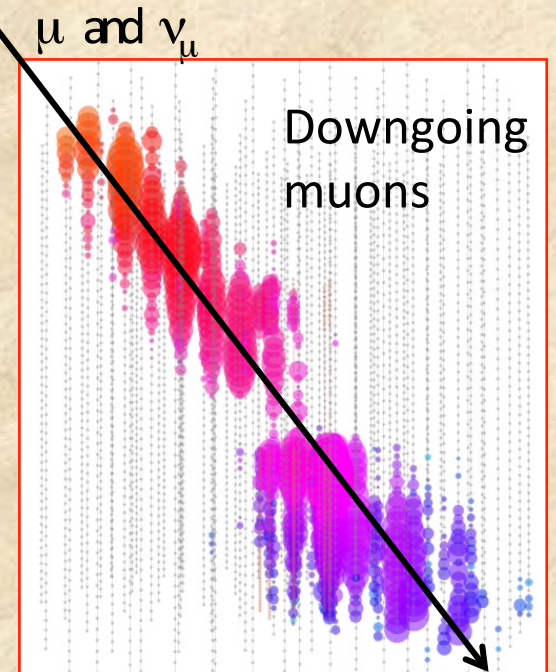
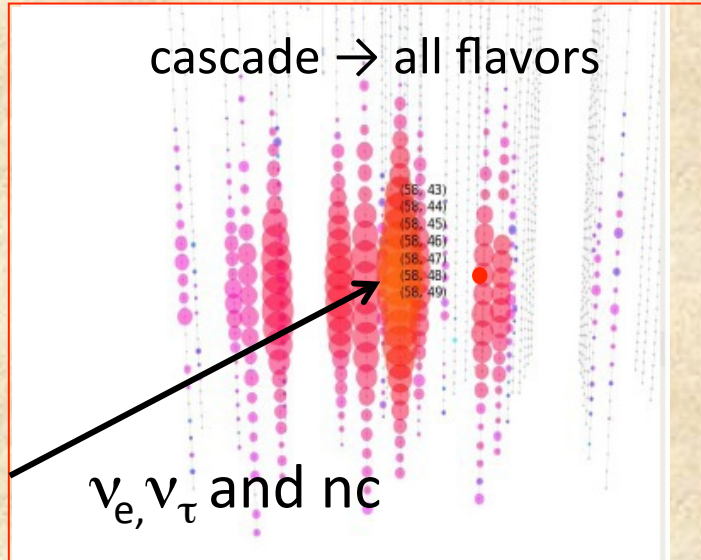
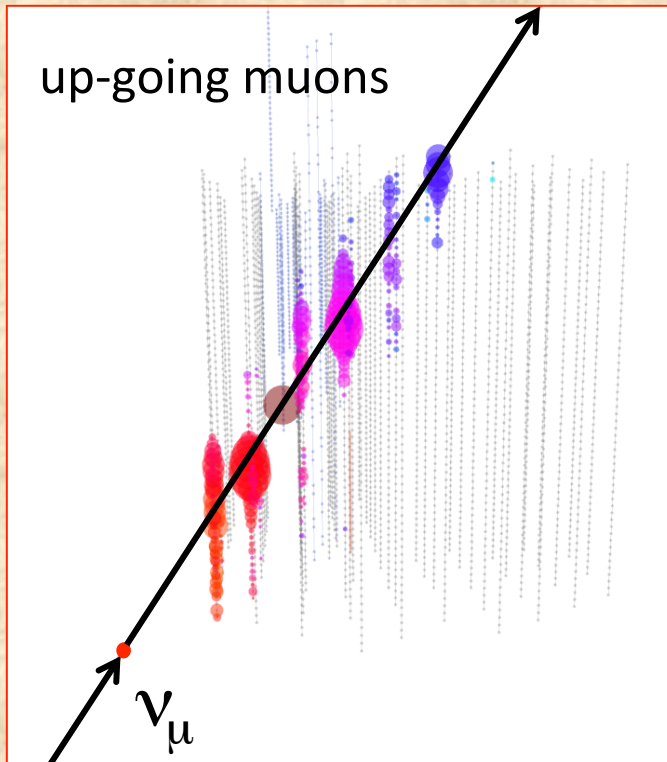

light collection by DOMs

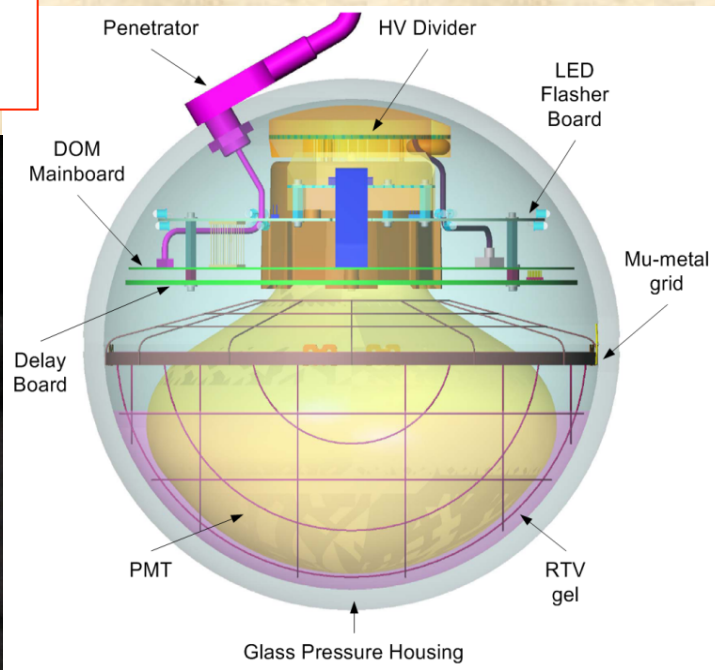

## Digital Optical Module (DOM)

- Low Noise rate (500 Hz)
- High reliability, very few sensor issues per year.
- Gains very stable to  $<0.3\%$ .
- Digital communication from DOM

# Search Strategies for Astrophysical Neutrinos

Atmospheric Neutrinos produced terrestrially by cosmic ray interactions in the atmosphere

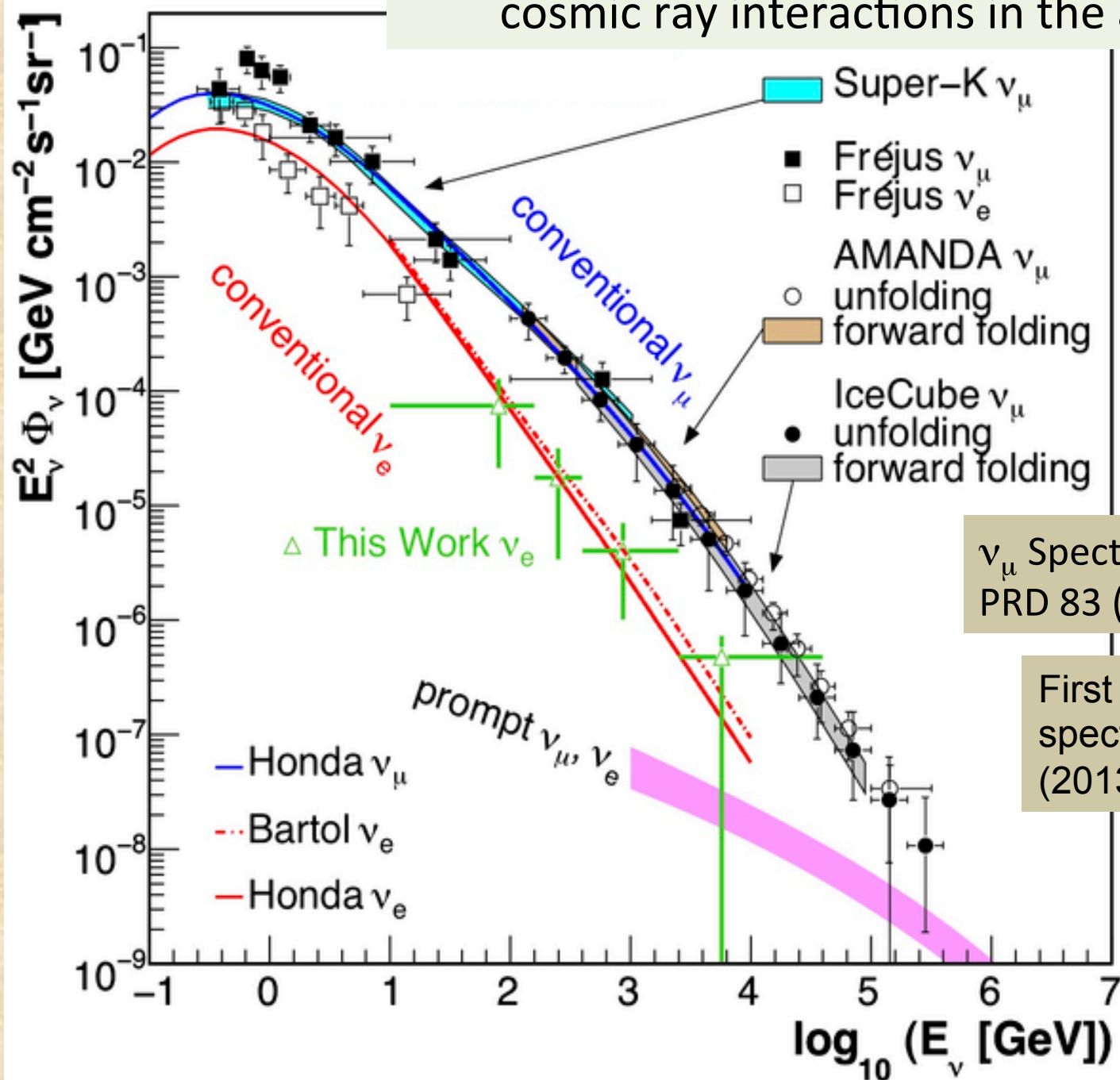

$\nu_\mu$  Spectrum  
PRD 83 (2011) 012001

First atmospheric  $\nu_e$   
spectrum (green) PRL 110  
(2013) 151105

# Search Strategies for HE Astrophysical Neutrinos

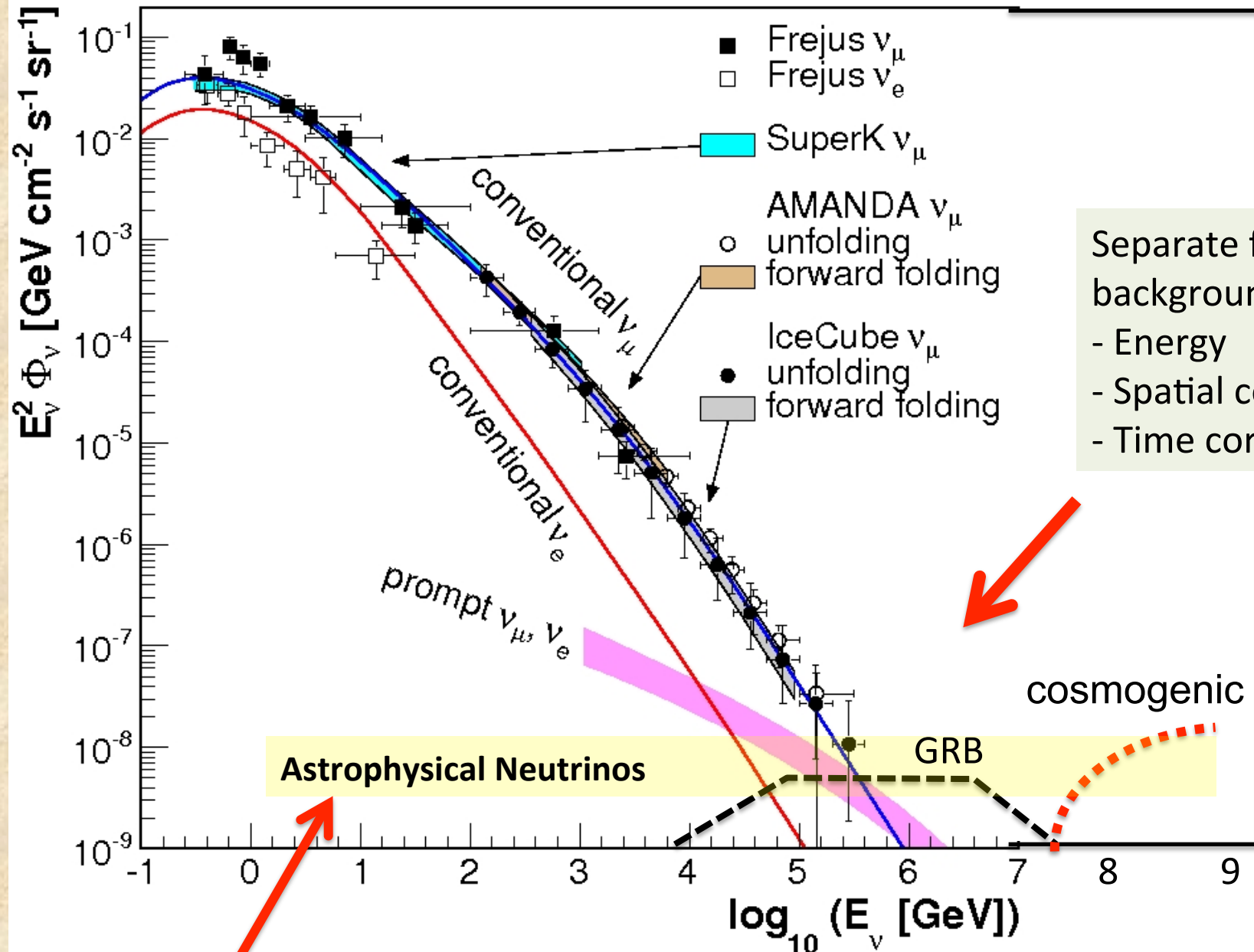

Separate from background using:

- Energy
- Spatial correlation
- Time correlation



Motivates requirement of at least 1 km<sup>3</sup>

# IceCube Detector Data Runs

| Strings      | Data (year) | Livetime  | trigger rate (Hz) | HE $\nu$ rate (per day) |
|--------------|-------------|-----------|-------------------|-------------------------|
| AMANDAII(19) | 2000-2006   | 3.8 years | 100               | ~5 / day                |
| IC40         | 2008-09     | 375 days  | 1100              | ~40/ day                |
| IC59         | 2009-10     | 350 days  | 1900              | ~70/ day                |
| IC79         | 2010-11     | 320 days  | 2250              | >100/day                |
| IC86-1       | 2011- 2012  | ~ year    | 2700              | ~200/day                |
| IC86-2       | 2012-2013   | ~year     | 2700              | ~200/day                |
| IC86-3       | 5/13 – 5/14 | running   | 2700              |                         |

DeepCore Installed



*Run transition near May 1*

**IC86 achieving > 99% uptime**



# Outline

- Impact of High Energy Neutrinos with IceCube and implications for “Neutrinos Beyond IceCube”
  - High Energy Diffuse Neutrinos
    - First evidence for high energy astrophysical neutrinos (Science 2013) → opens the era of HE  $\nu$  astrophysics!
    - Consistent with projections based upon the flux of high energy cosmic rays... many questions arise... know science is possible
    - ***Opens the era of neutrino astrophysics – neutrinos are there!***
  - High Energy Gamma Ray Burst (GRB) Neutrinos
    - IceCube’s 2012 Nature Paper using IC40/59 data has ruled out GRB as the source of high energy cosmic rays!
    - And... Stimulated a reevaluation of the astrophysical models for neutrino production in GRB fireball model
    - now at sensitivity of these “new” models → observation(?) would open ***another*** exciting era of particle physics and astrophysics

# IceCube diffuse EHE astrophysical neutrino searches

- At Neutrino 2012
  - IceCube had achieved sensitivity to diffuse neutrinos at about Waxman-Bahcall flux with data from partial detector
  - Upward fluctuation in 59-string  $\nu_\mu$  data ( $1.8\sigma$ )
  - **IC79, IC86-1 EHE (GZK neutrino) Search**
    - **2 events at  $\sim 1$  PeV found in data ( $2.8\sigma$ )**
    - **Low energy threshold for GZK search**
- Motivated the High Energy Starting Event search (HESE)
  - Extend sensitivity to events below EHE search low energy threshold
  - All flavor search uses tracks and cascades
  - 2 years data from  $\rightarrow$  IC79, IC86-1 (662 days live time)
    - Found  $4\sigma$  excess  $\rightarrow$  evidence for HE astrophysical neutrinos published in 2013
  - Add IC86-2 as third year to HESE data (988 days live time)
  - IC79,86-1  $\nu_\mu$  diffuse neutrino search as supporting evidence

Updated  
here

# 2 events found at threshold $\sim 1$ PeV

2.8 $\sigma$  excess over backgrounds from terrestrial sources

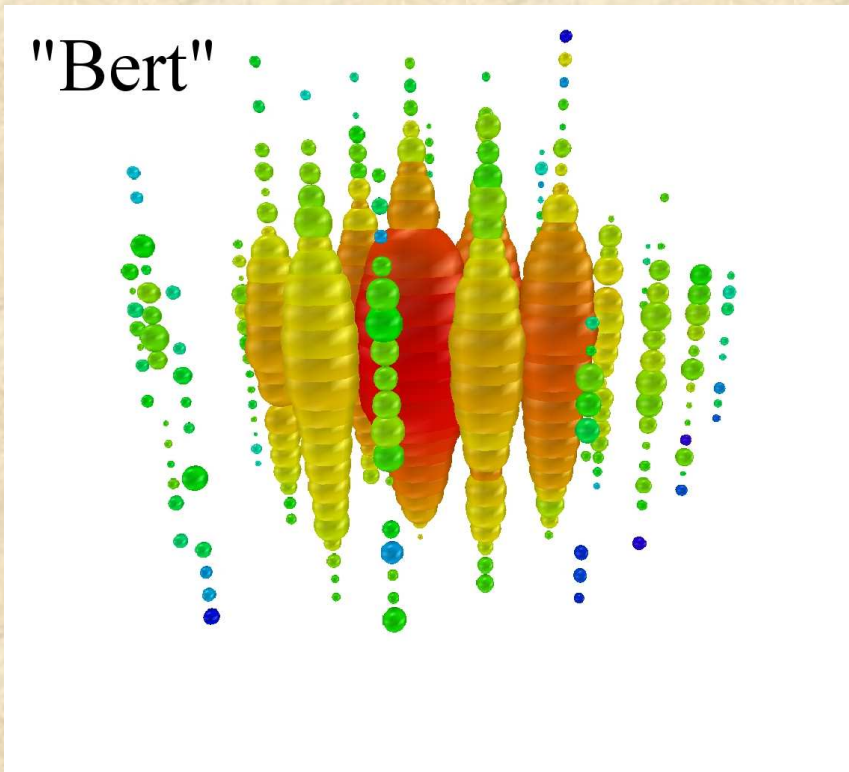

"Bert"  
 $\sim 1050$  TeV

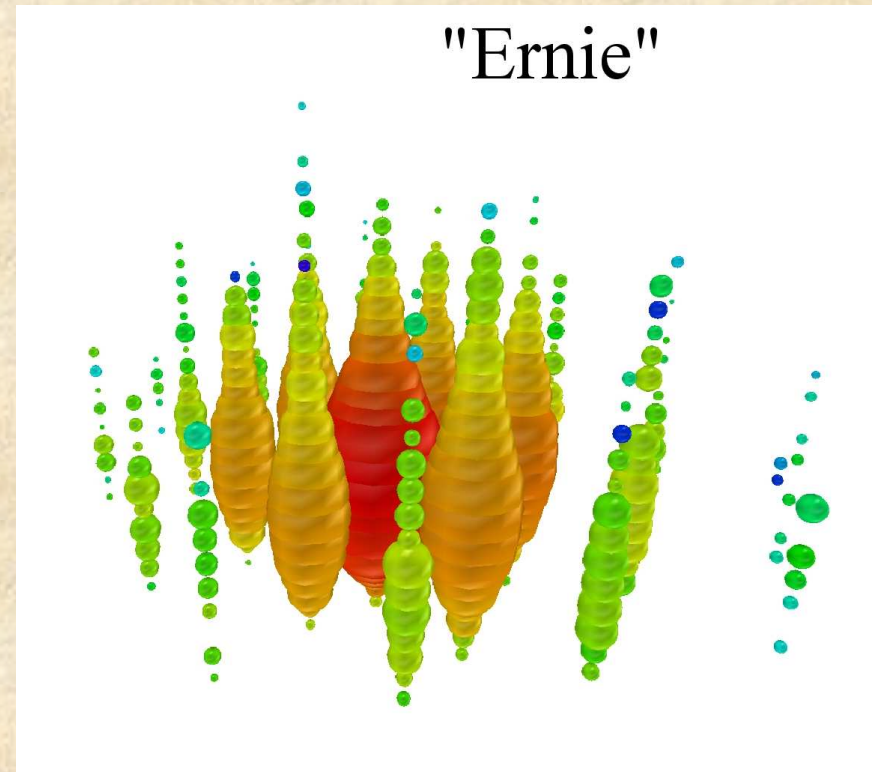

"Ernie"  
 $\sim 1150$  TeV

# IceCube diffuse EHE astrophysical neutrino searches

- At Neutrino 2012
  - IceCube had achieved sensitivity to diffuse neutrinos at about Waxman-Bahcall flux with data from partial detector
  - Upward fluctuation in 59-string  $\nu_\mu$  data ( $1.8\sigma$ )
  - IC79, IC86-1 EHE (GZK neutrino) Search
    - 2 events at  $\sim 1$  PeV found in data ( $2.8\sigma$ )
    - Low energy threshold for GZK search
- Motivated the High Energy Starting Event search (HESE)
  - Extend sensitivity to events below EHE search low energy threshold
  - All flavor search uses tracks and cascades
  - 2 years data from  $\rightarrow$  IC79, IC86-1 (662 days live time)
    - **Found  $4\sigma$  excess**  $\rightarrow$  evidence for HE astrophysical neutrinos published in 2013
  - Add IC86-2 as third year to HESE data (988 days live time)
  - IC79,86-1  $\nu_\mu$  diffuse neutrino search as supporting evidence

Updated  
here

# High Energy Start Event (HESE) search

- find more contained events
- total calorimetry
- complete sky coverage
- flavor determined
- some will be muon neutrinos with good angular resolution

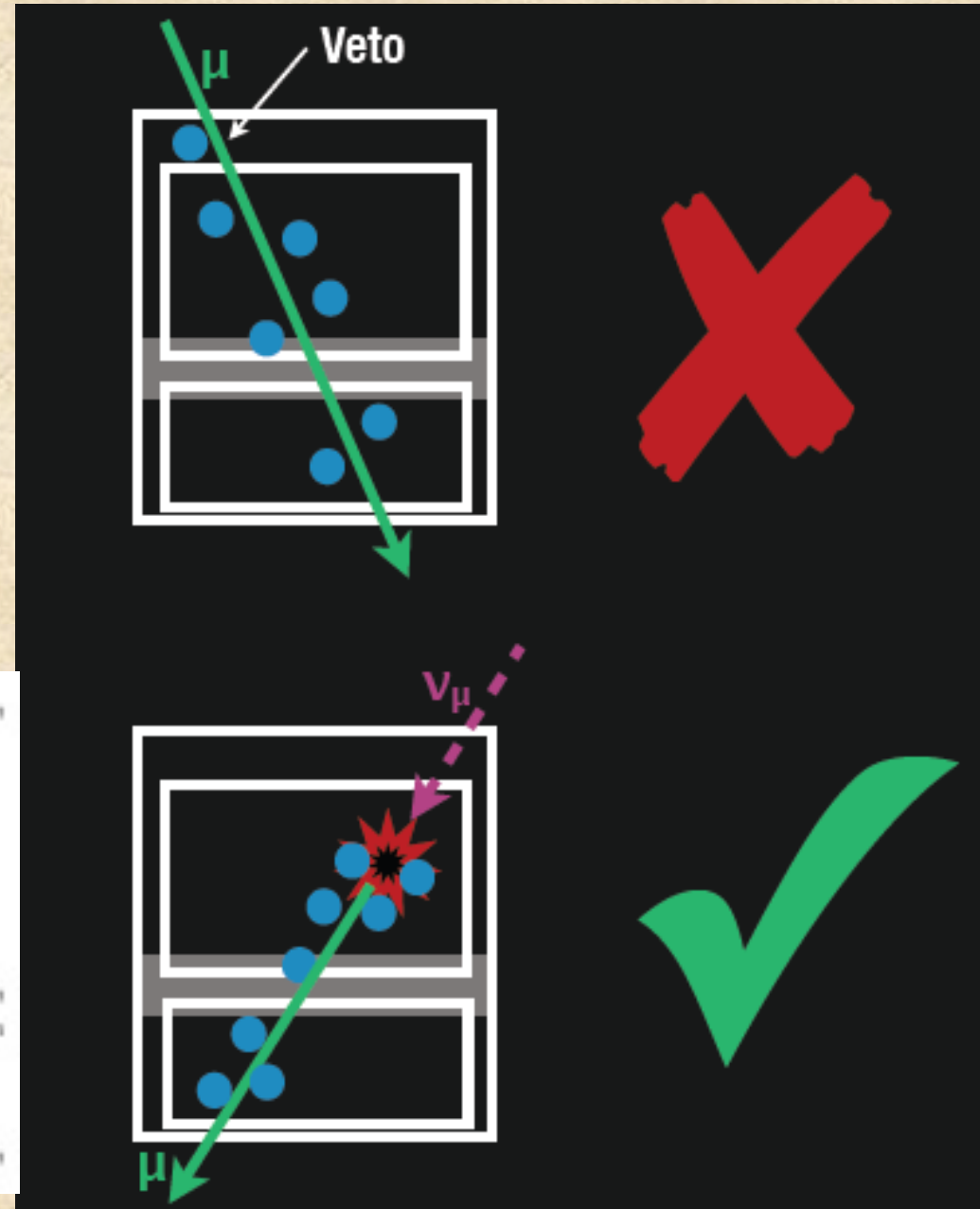
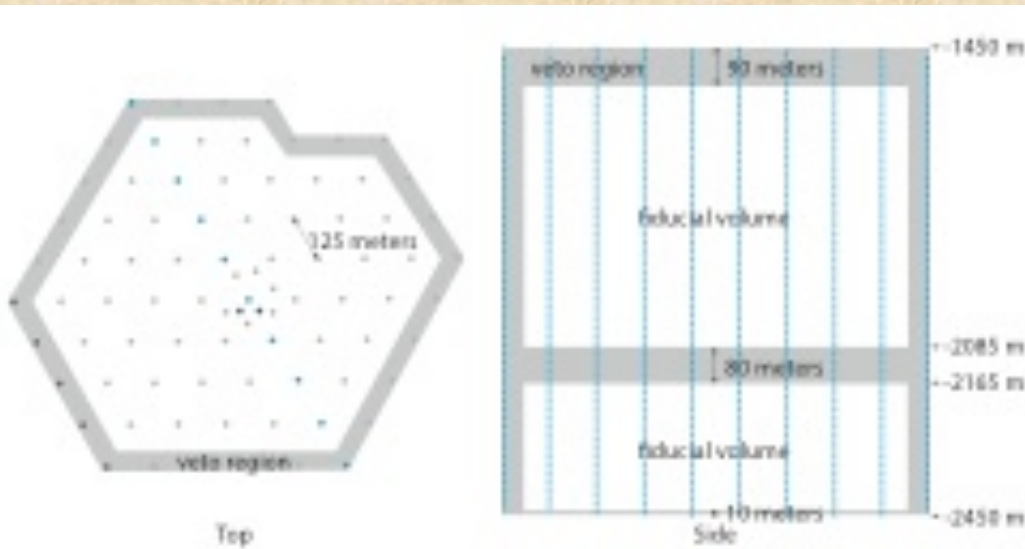

# HE Neutrino Diffuse Results

Science 22 November 2013:  
Vol. 342 no. 6161

- *Last year IceCube published the first evidence for high energy astrophysical neutrinos using 2 years of data*
  - IC79,86-1 “HESE” analysis
  - 28 events detected
  - Evidence at the  $4\sigma$  level

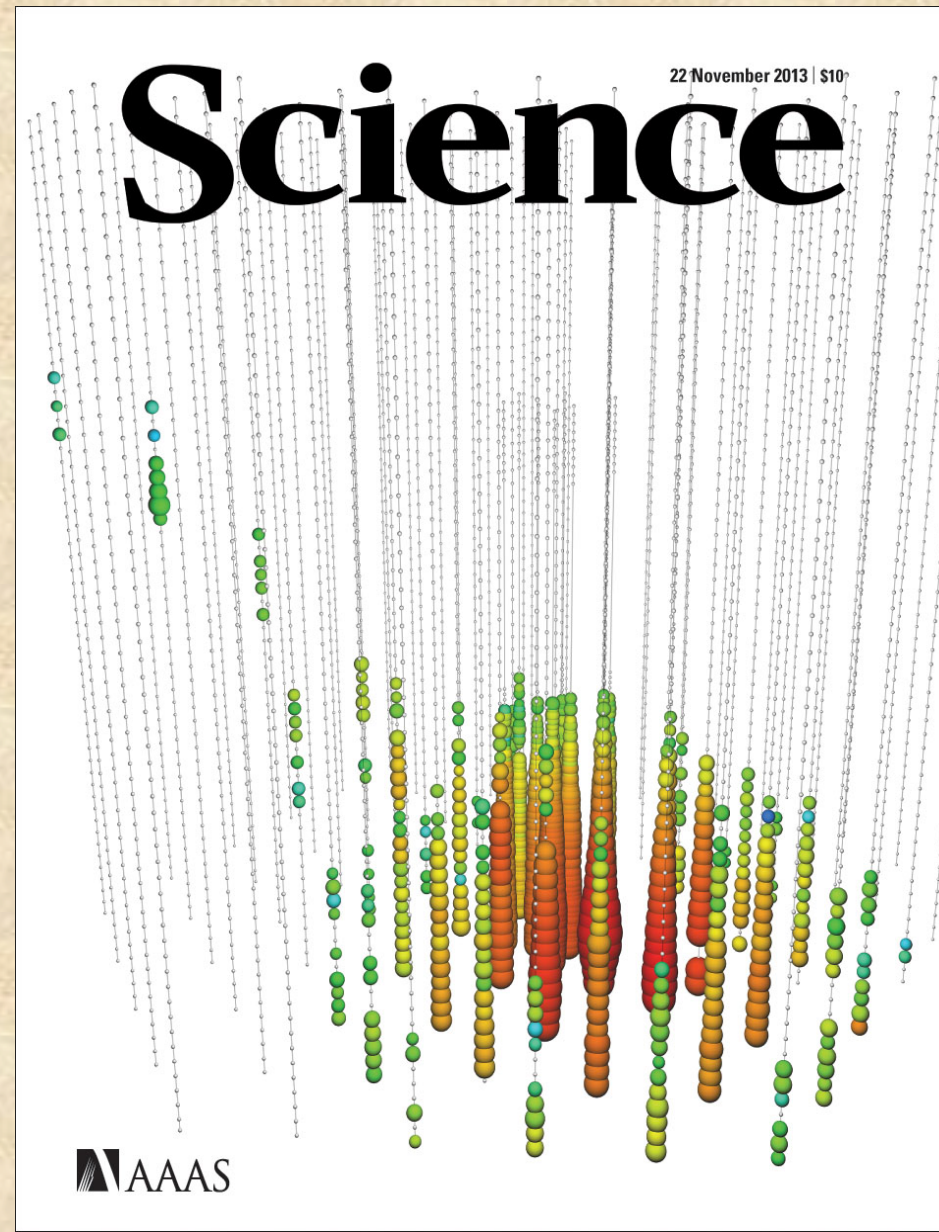

# IceCube diffuse EHE astrophysical neutrino searches

- At Neutrino 2012
  - IceCube had achieved sensitivity to diffuse neutrinos at about Waxman-Bahcall flux with data from partial detector
  - Upward fluctuation in 59-string  $\nu_\mu$  data ( $1.8\sigma$ )
  - IC79, IC86-1 EHE (GZK neutrino) Search
    - 2 events at  $\sim 1$  PeV found in data ( $2.8\sigma$ )
    - Low energy threshold for GZK search
- Motivated the High Energy Starting Event search (HESE)
  - Extend sensitivity to events below EHE search low energy threshold
  - All flavor search uses tracks and cascades
  - 2 years data from  $\rightarrow$  IC79, IC86-1 (662 days live time)
    - Found  $4\sigma$  excess  $\rightarrow$  evidence for HE astrophysical neutrinos published in 2013
  - Add IC86-2 as third year to HESE data (988 days live time)
  - IC79,86-1  $\nu_\mu$  diffuse neutrino search as supporting evidence

Updated  
here

# Updated HESE Results (3 Year)

- 988 day sample
- detected 37 events
- expected background of  $8.4 \pm 4.2$  cosmic ray muon events and  $6.6+5.9$  atmospheric neutrinos.

5.7 $\sigma$

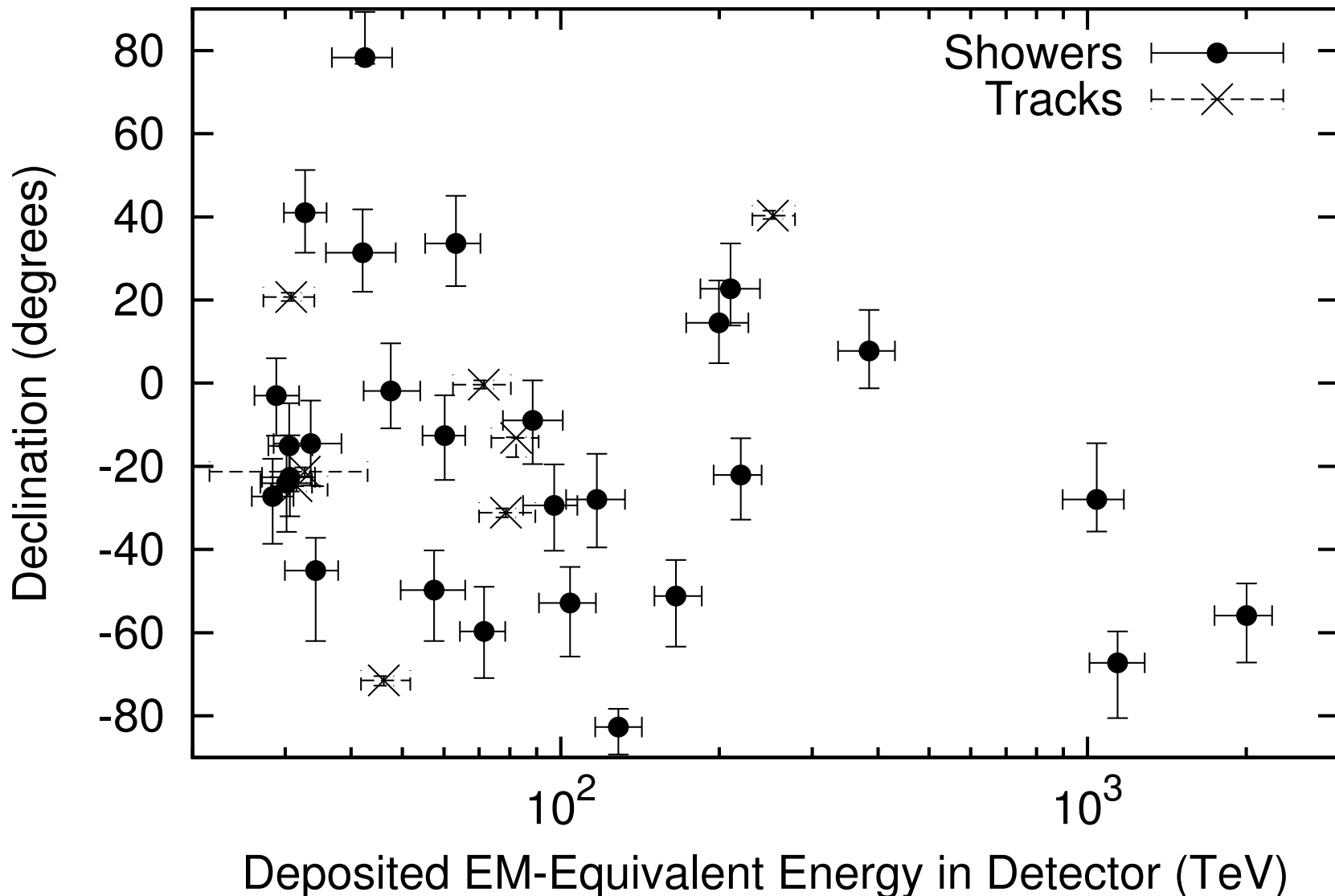



# HESE 3 Year Results

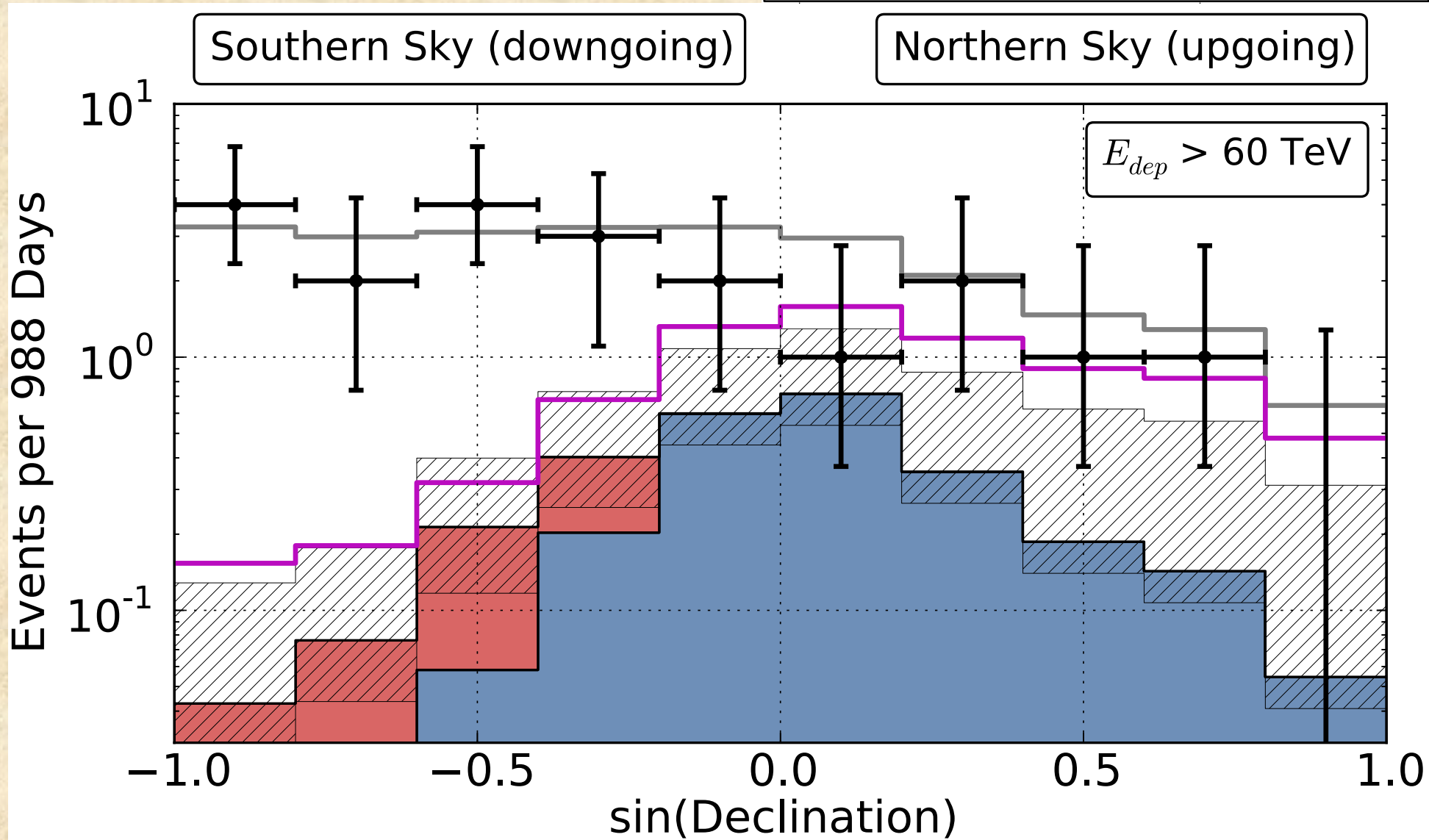
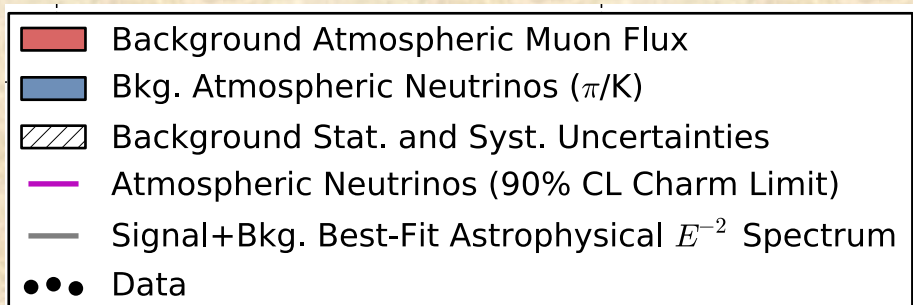

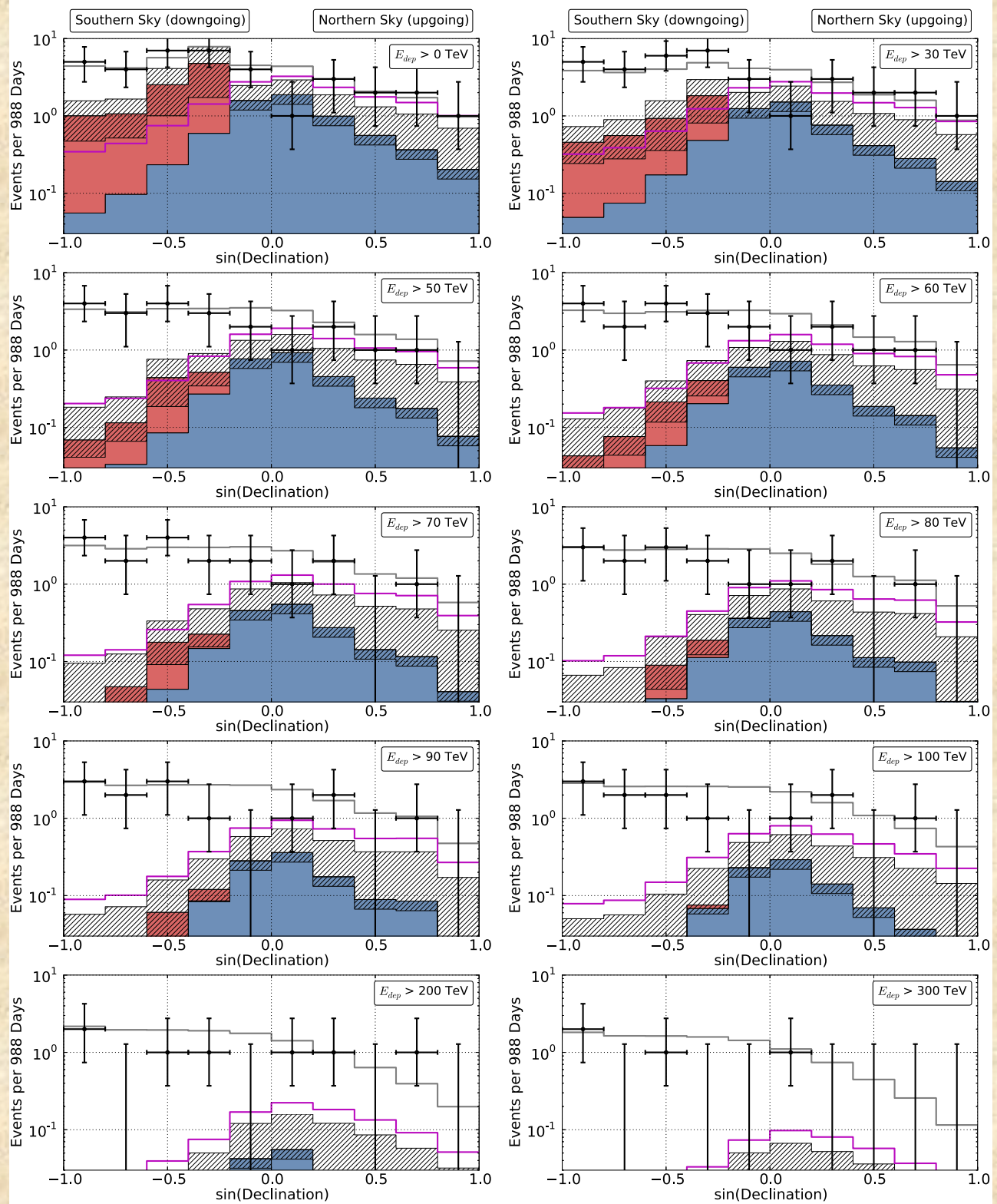
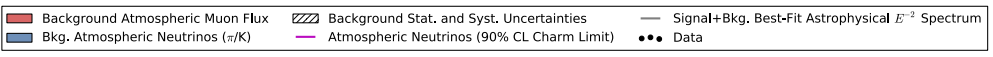

# HESE 3 Year Results

best-fit per-flavor astrophysical( $E^{-2}$ ) flux  
in the energy range of 60 TeV – 3 PeV  
 $E^2\phi(E) = 0.95 \pm 0.3 \times 10^{-8} \text{ GeV cm}^{-2} \text{ s}^{-1} \text{ sr}^{-1}$

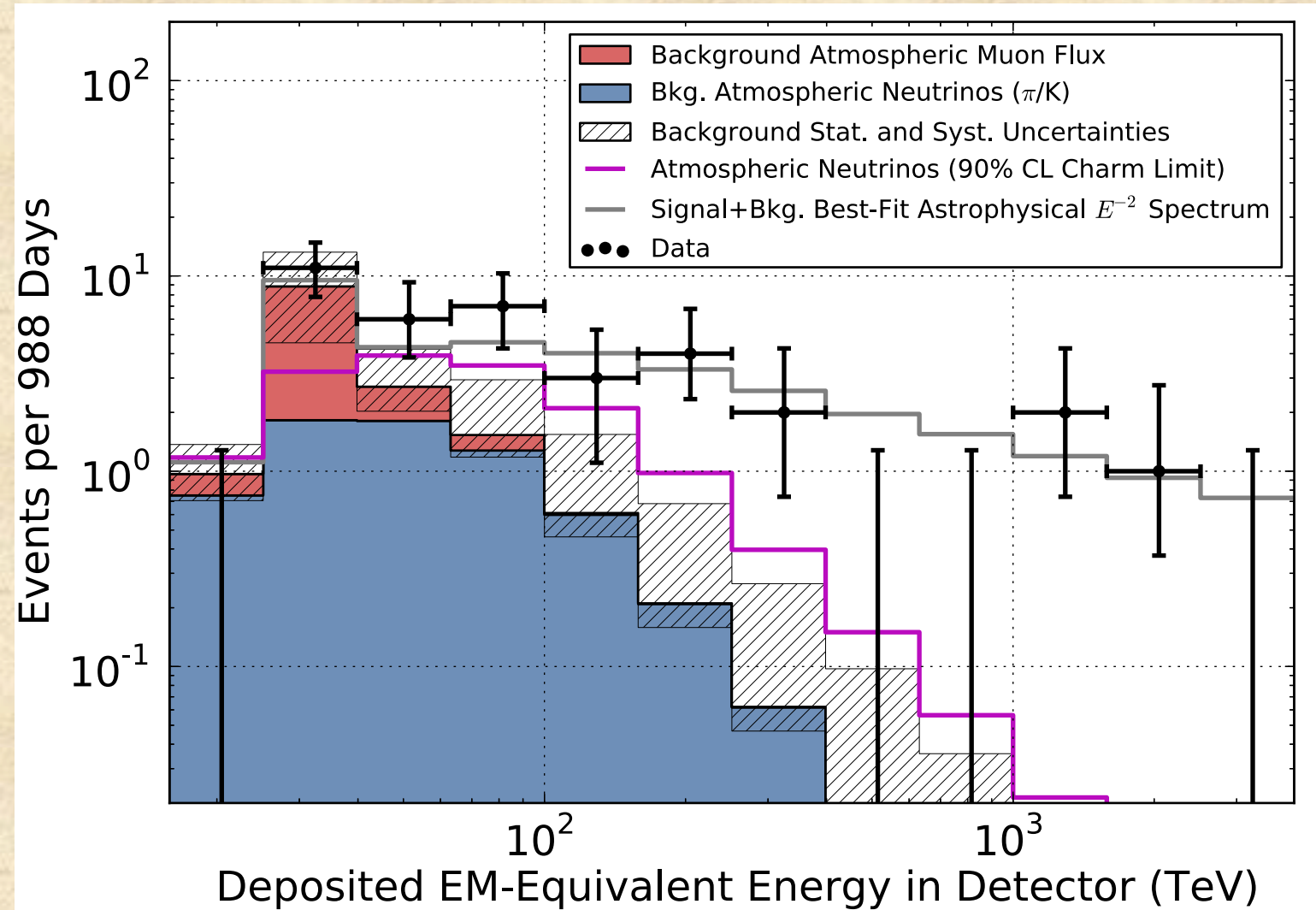

- consistent with  $E^{-2}$
- indication of a cutoff around 2 PeV above which 4.1 events would be expected from a flux at our best-fit level
- The range of best fit slopes of -2.0 to -2.3.

# HESE 3 Year Results

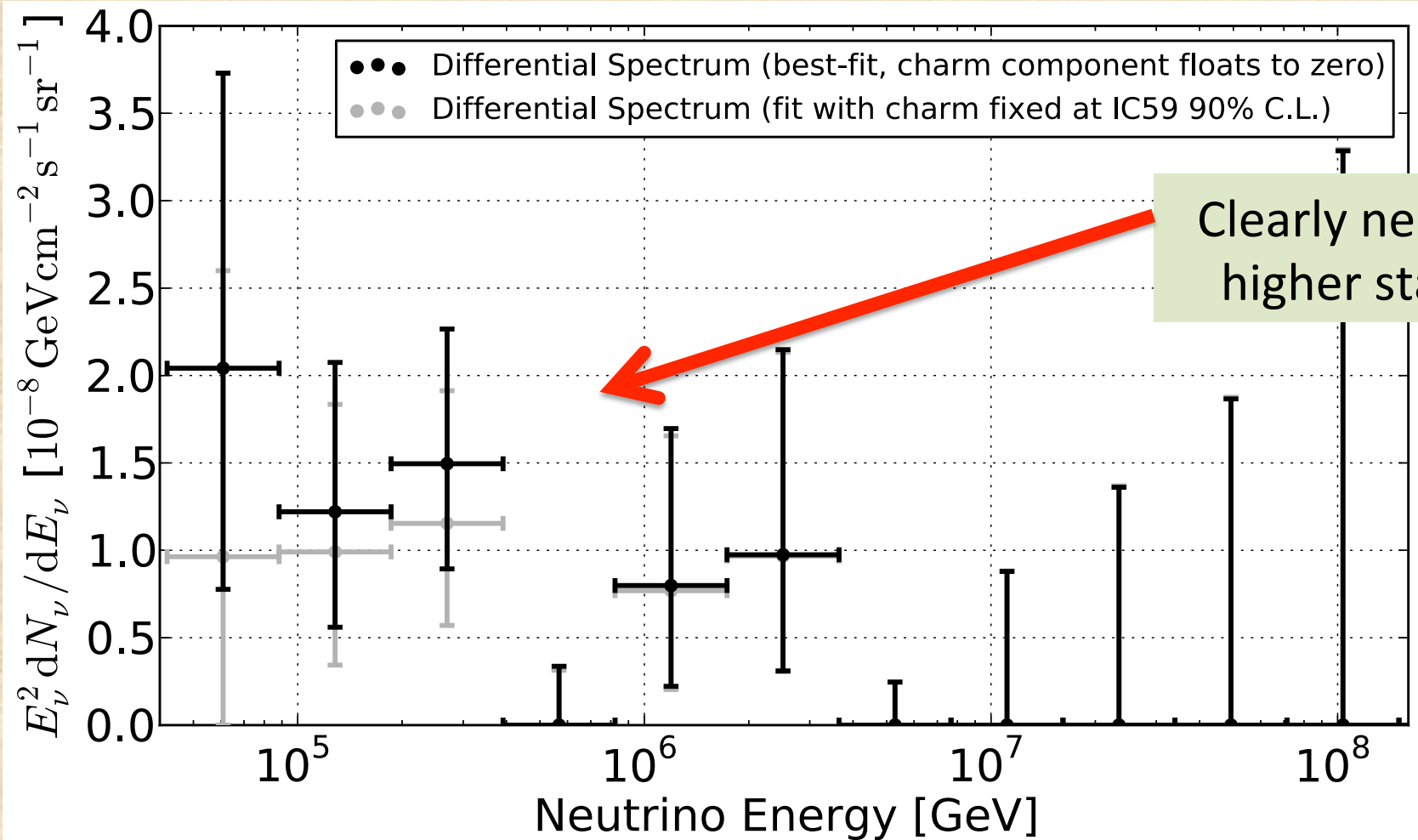

The best-fit power law is:

$$E^2\phi(E) = 1.5 \times 10^{-8} (E/100\text{TeV})^{-0.3} \text{ GeV cm}^{-2} \text{ s}^{-1} \text{ sr}^{-1}$$

# HESE 3 Year Results

Showers only  
post trial p-value = 7.2%

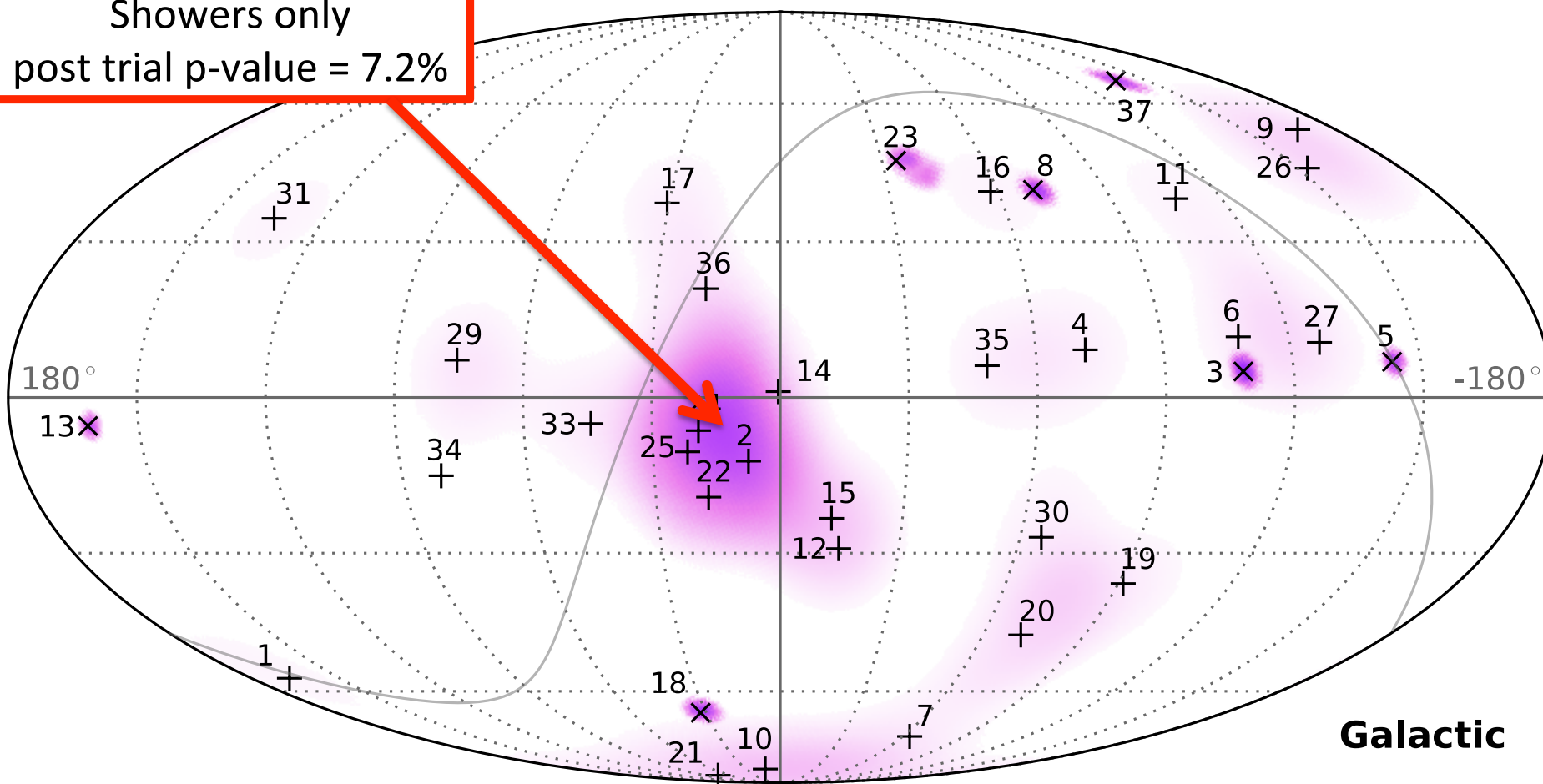

# IC79,86-1 $\nu_\mu$ diffuse neutrinos

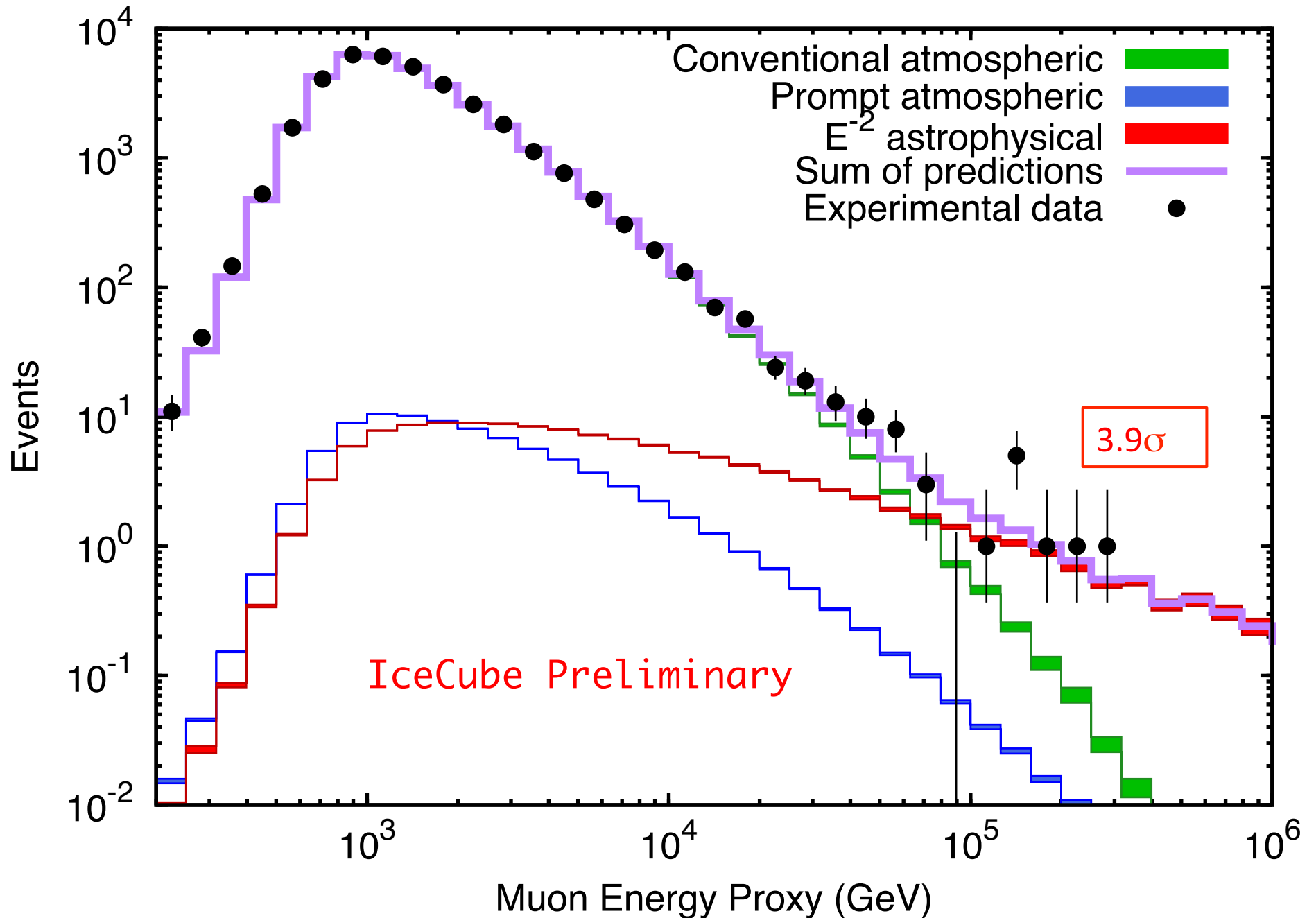

# High Energy Neutrinos

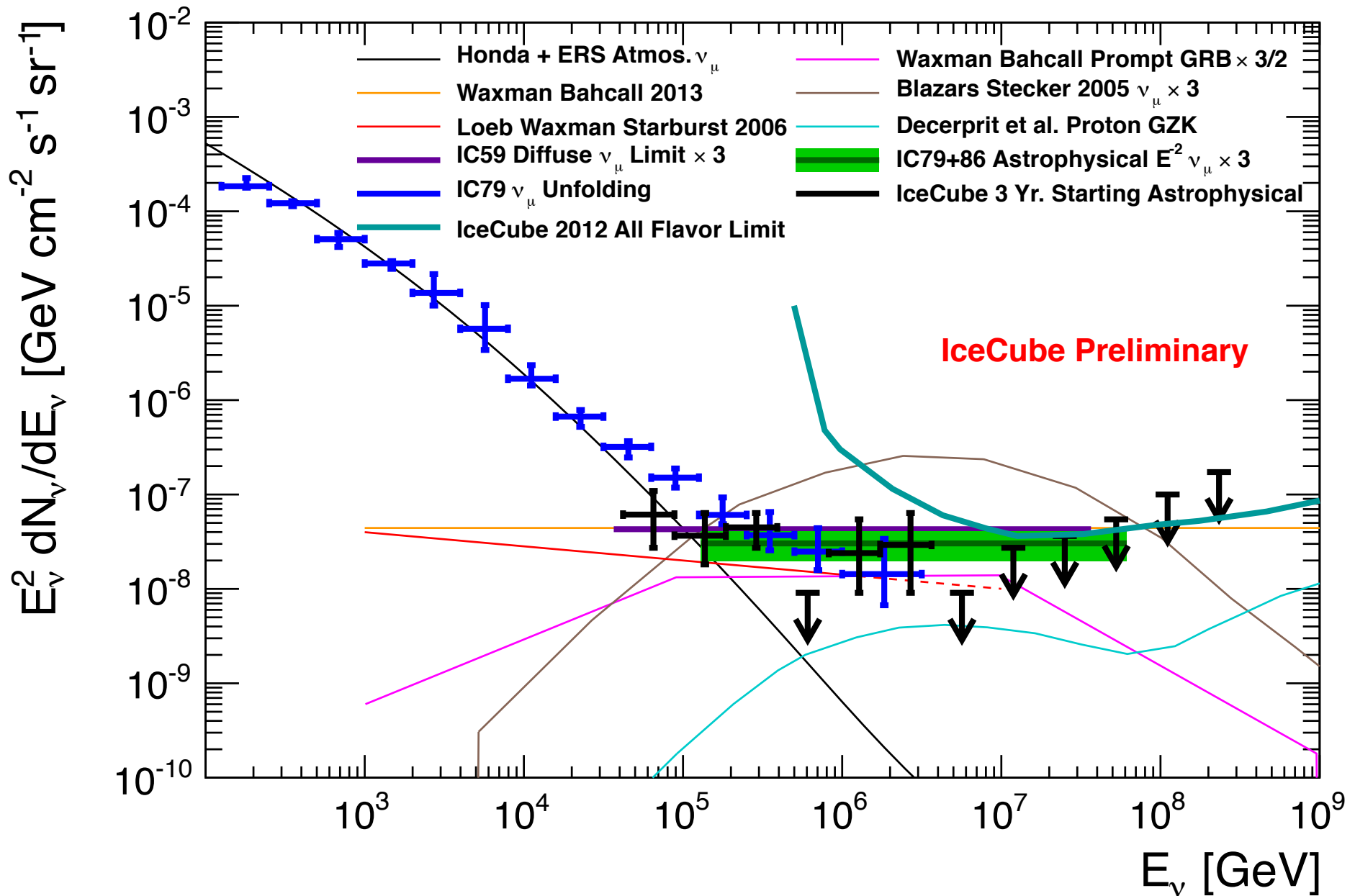

# HE Astrophysical Neutrinos?

- High energy astrophysical neutrinos are detected
  - *astrophysics and particle physics within reasonable reach!*
- Many questions about the HE Neutrinos with astrophysics and particle physics implications
  - What are the unknown sources and the origin of cosmic rays?
    - Clustering and point source searches
    - Tracks events with better angular resolution
  - What are the high energy production mechanisms?
    - Spectral Index, spectral cutoff, Glashow resonance
    - Flavor content
- We know the flux is there
  - Need more data to answer these questions



# Implications for Neutrinos Beyond IceCube

- Scaling the number of HESE events with  $E > 500$  TeV = 3 ( $>1.1$  at 90% c.l.)
  - +7 years  $\approx$  10 events
    - ( $> 3.7$  at 90%)
  - x5 (50 years equivalent)  $\approx$  50 events
    - ( $>18.3$  at 90%)
- Muons above 300 TeV ( $\sim 20\%$  of total), which give good pointing!
  - +7 years  $\rightarrow N_{\mu} \approx 2$  events
    - ( $> 0.74$  at 90%)
  - x5 = 50 years equivalent  $\rightarrow N_{\mu} \approx 10$  events
    - ( $> 3.7$  at 90%)

# Gamma Ray Bursts

- Gamma-Ray Bursts are short bursts of gamma rays, few-100 seconds in duration
- Brighter than rest of gamma ray sky
  - Afterglow lasting much longer
- Several generations of satellite-based observations have shown:
  - Extra-galactic origin
  - Gamma-ray emission beamed
- Internal shocks in GRBs were a compelling candidate for the source of acceleration for UHECRs.

Beamed emission in Jet

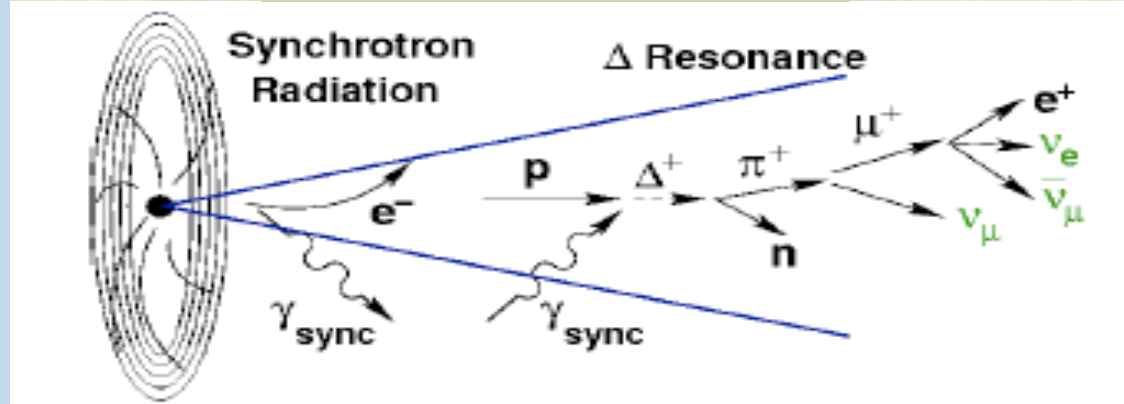

GRB in Gamma-Rays

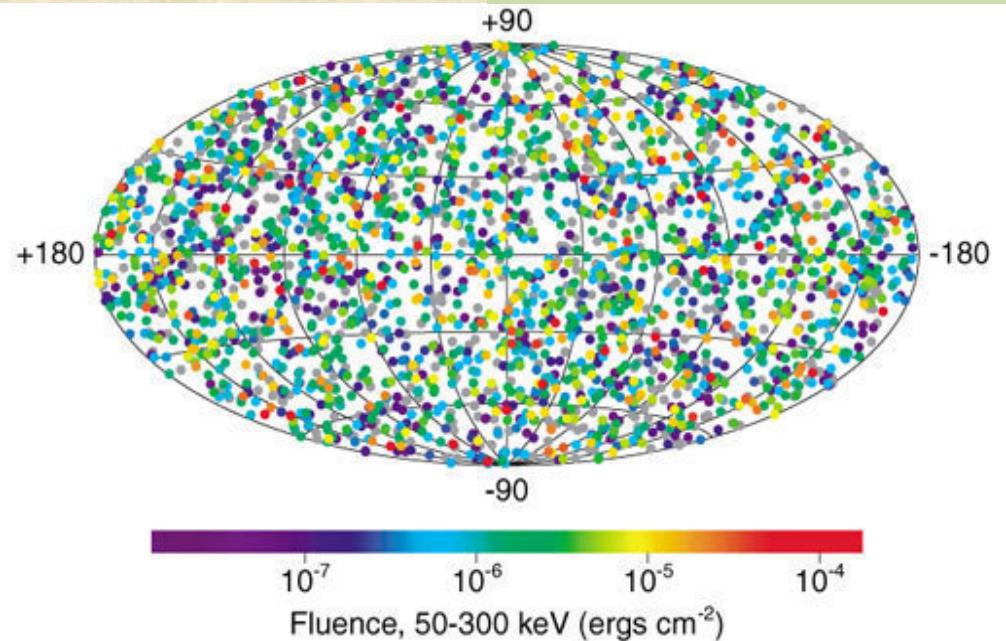

- Model dependent stacked search for a neutrino signal in coincidence with observed GRB gamma signals
  - Northern hemisphere GRB bursts are considered.
  - Spatial & time correlation yields very low background (***~Background Free Search***)
- Model independent search more generic on wider time-scale
  - Up to  $\pm 1$  day and with generic ( $E^{-2}$ ) spectrum

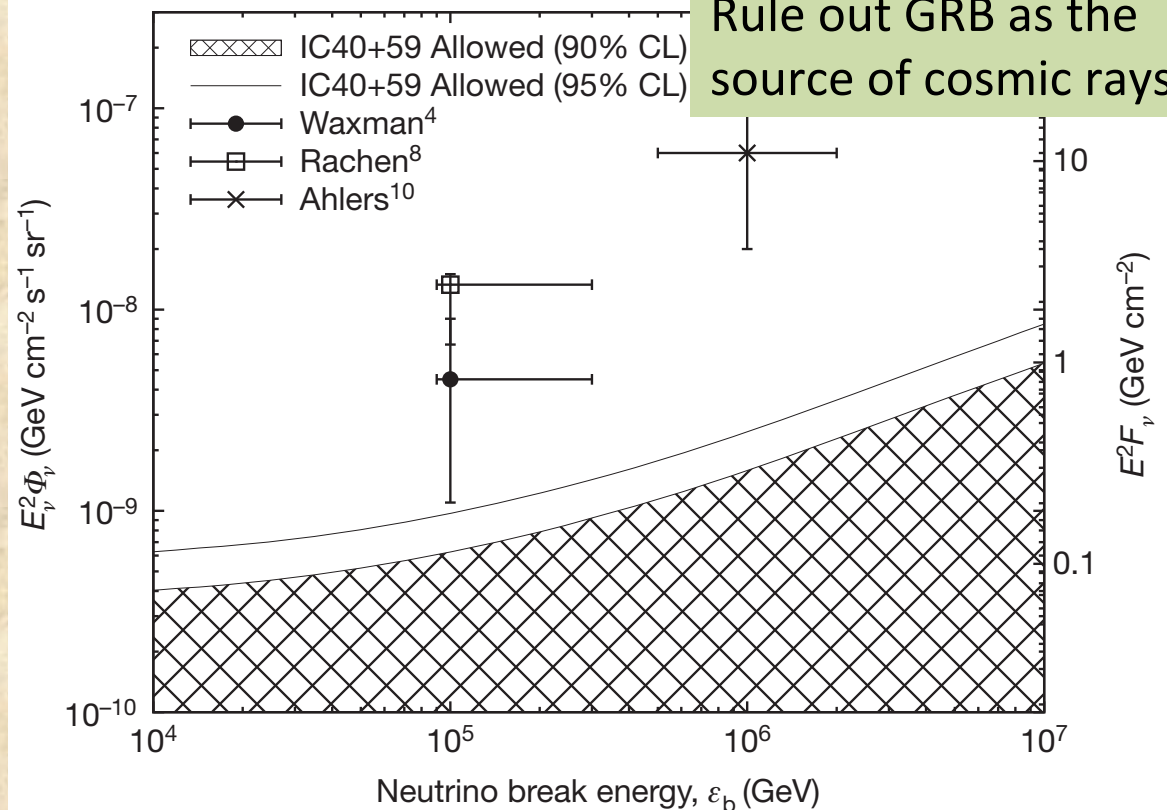
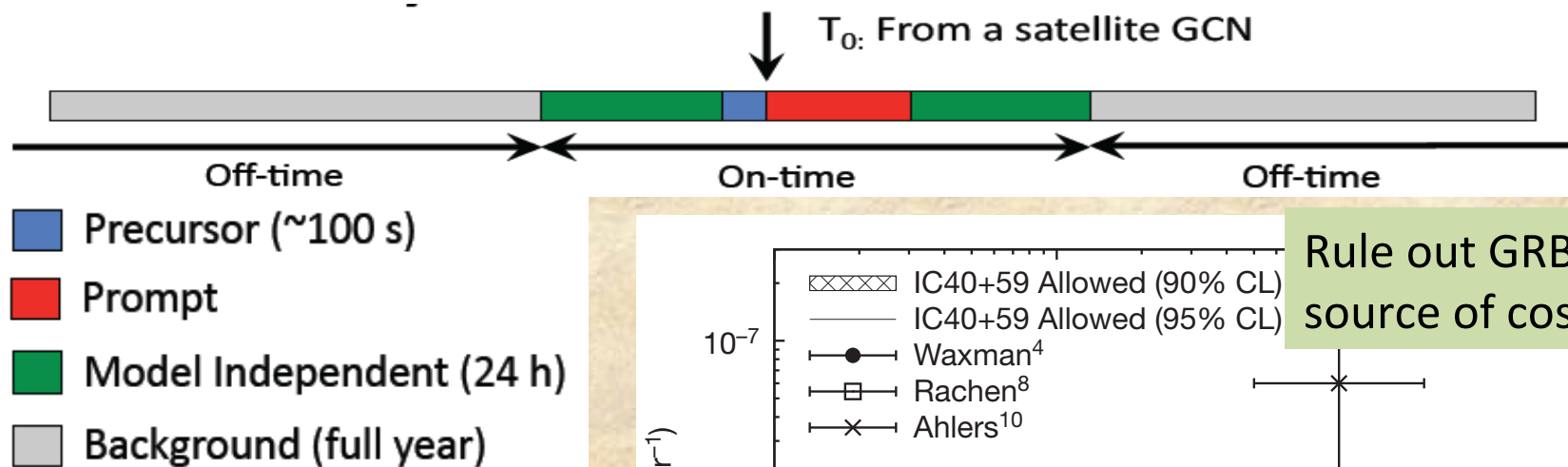

**Nature Vol 484, 351  
(2012)**

Using IC40/IC59  $\nu_\mu$  data

# GRB Neutrinos a brief history

IC40/59 model dependent result (2011-2012)

- Ruled out GRB as the UHCR source
- Set limit below fireball models

Models reevaluated (after Nature Paper)

- Current data now approaching models (2014)

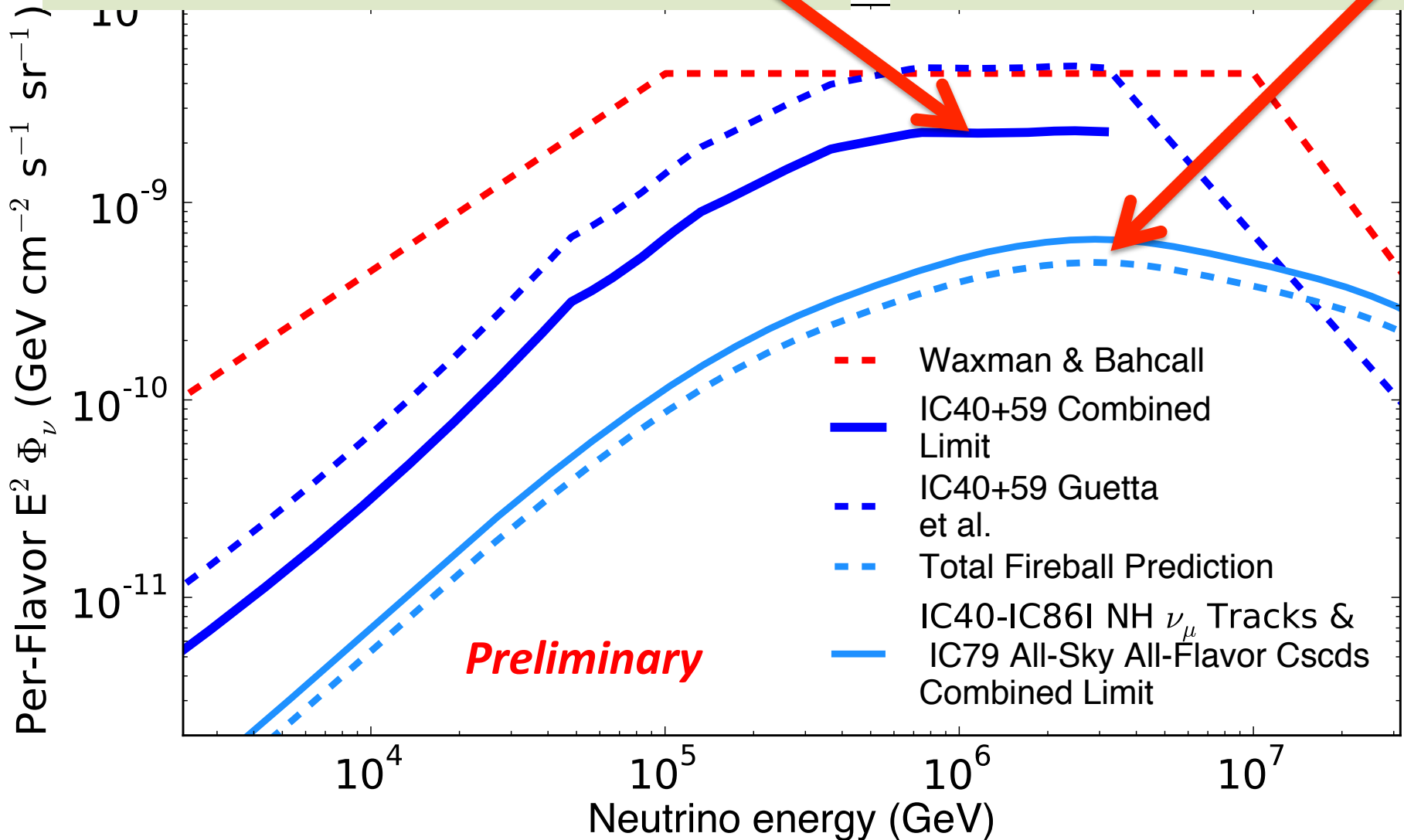

# Are We Starting to See GRB neutrino flux?

## IC79 Cascade GRB search

- Expected signal events per search, season:
  - NH Track Searches:** 0.27 (IC40), 0.66 (IC59), 0.23 (IC79), 0.34 (IC86)
  - All-Sky Cascade Search:** 0.26 (IC79)
- IC40-86 NH track search:
  - Total expected  $\nu$  events:** 1.5
  - Total events seen:** 0
  - 90% UL:** 1.54 x model flux
- IC40-86 NH track + IC79 All-Sky cascade search:
  - Total expected  $\nu$  events:** 1.76
  - Total events seen:** 1
  - 90% UL:** 1.31 x model flux

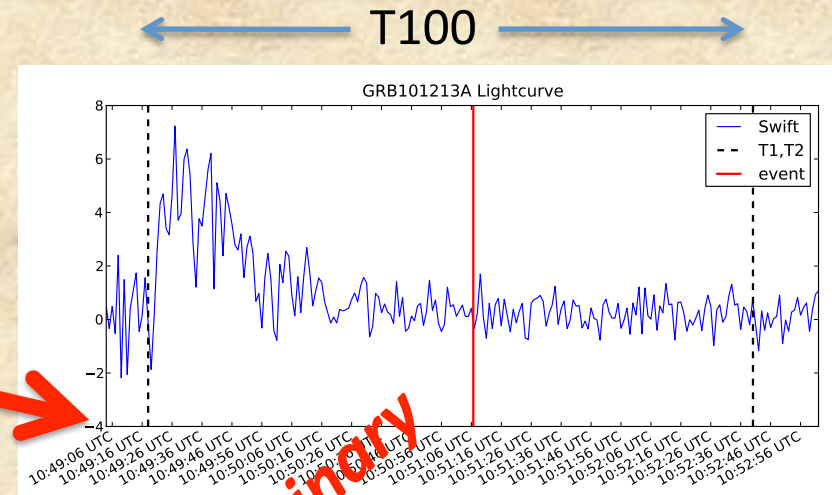

Not yet significant...

### Resulting Test Statistic:

|               |       |
|---------------|-------|
| $\mathcal{T}$ | 0.17  |
| p             | 11.4% |
| p (sigmas)    | 1.2   |

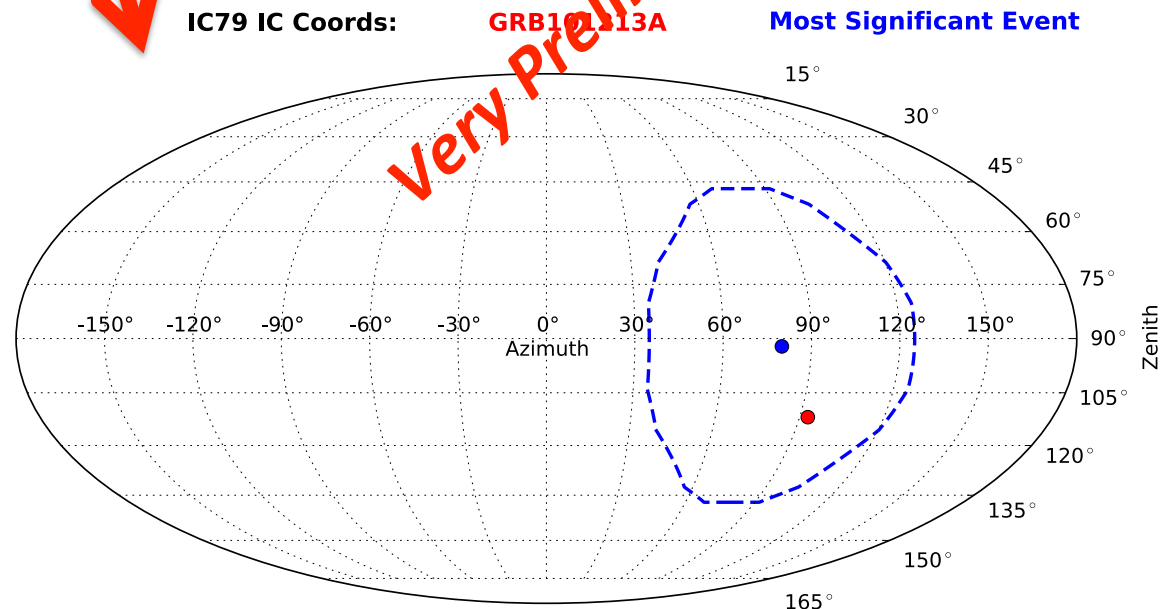

# IceCube HE GRB Summary

- Combined (IC40, IC59) search results → *Nature Paper*
  - *Rule out GRB as THE source of HE cosmic rays*
  - *Stimulated new astrophysical modeling of neutrino production*
    - *Resulted in lowering of prediction for neutrino flux*
- IC79, 86-1 Track search *Preliminary*
  - No observation of signal
  - Sensitivity near the new predictions
- Added IC79 Cascade search *Very Preliminary*
  - See one event with expected 1.7 from current models
    - *Not significant ( $1.2\sigma$ )*
- Will soon add IC86-2,3 to track search and IC86-1,2,3 to Cascades
  - Very soon go from 4yr (track) + 1yr Cascade to 6 yr (track)+4 yr (cascade) → doubled exposure
  - 1 event now → ... *wait and see?*

# Implications for Neutrinos Beyond IceCube

- **assumption** that current models are about accurate and use the 1 event we have as the mean rate
  - Have 1 event in 4yr of mu and 1yr cascade = 5 “GRB-yr” or 2.5 years of combined (track+cascade) exposure
  - Soon add 2 years track and 3 years cascade = 5 years
    - Doubled exposure and reach limit setting potential below current models
  - Double that with 5 more years by around 2020?
    - ~few events with large uncertainty.
  - **caveat** (still theory based), Low statistics
    - Even if assumption is accurate may have only small number of events
- Beyond IceCube detector assuming X5 I3 equivalent
  - ~20 events (~2-4 GRB events per year depending on detector)
  - Would represent another breakthrough in HE neutrinos
    - Astrophysics
    - Particle physics

# Summary

- IceCube was designed as a discovery instrument
  - The first 1 km<sup>3</sup> detector. Volume required to reach the sensitivity of W-B flux motivated by cosmic ray flux
- IceCube was successfully constructed as an NSF MREFC, on time and on budget, with a performance exceeding the approved baseline requirements.
- IceCube has discovered diffuse astrophysical neutrinos!
  - We know the flux → opens questions on sources and mechanisms, and provides us with a basis on what we need to make astrophysical measurements and to maximize the science output
- The IceCube observatory represents an existing and well operated infrastructure within the NSF South Pole Facility.
  - Provides an ideal platform to leverage for the next generation detector for HE astrophysical neutrino precision measurements